

Drawing ID

C-15SSX

Product Info.

Finish	Code
Polish	C-15SSM
Satin	C-15SSS
Texture Black	C-15SSB

Dimensions

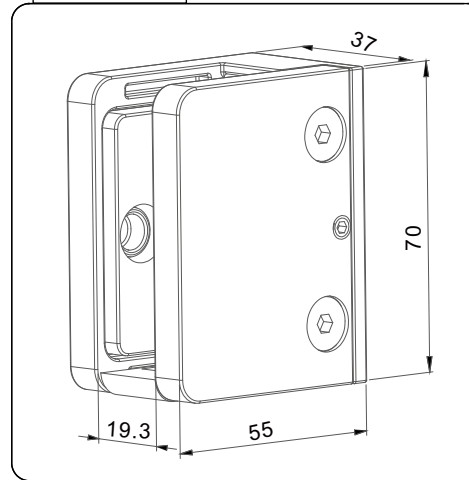

Removable Sitting Plate

Dimensions

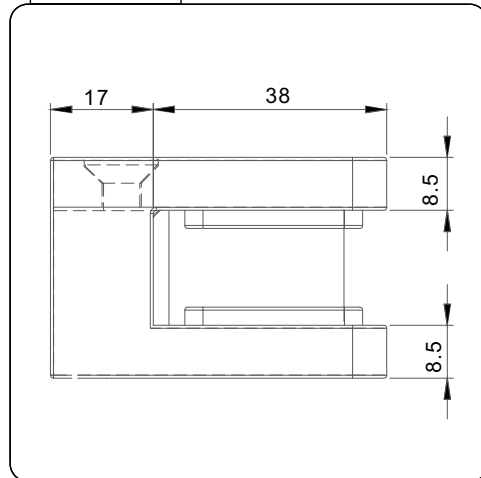

Hole Option

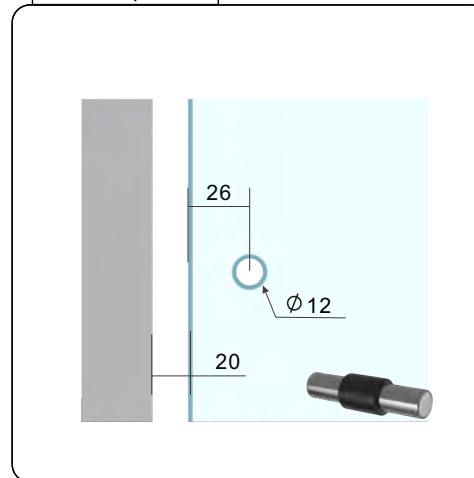

Top View

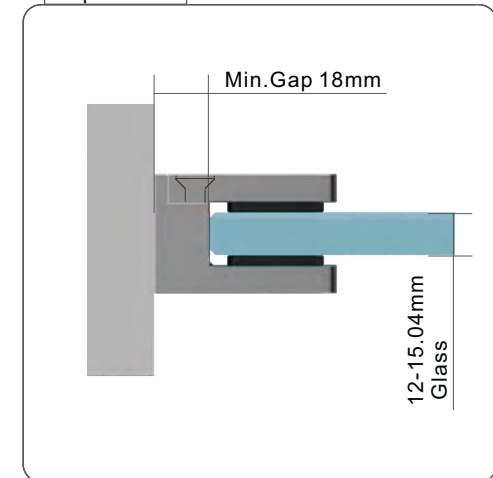

MATERIAL:

Duplex 2250 Stainless Steel

CATALOGUE AND DESCRIPTION:

- > Glass Fixing System
- > Glass Clamp
- > Heavy Duty Friction Fit Square Flat Back Glass Clamp

NOTES:

This drawing and or specification is the property of Silver Stone Hardware Pty Ltd - and must be returned to them on request. Unauthorised use may result in Legal Action. Its contents must not be made public, nor copied, nor used directly or indirectly in any way.

SILVER STONE HARDWARE PTYLID

56-62 Bryant Street, Padstow, NSW 2211
 T: (02) 9792 2955 M: 0452 526 680
 www.silverstonehardware.com.au
 sales@silverstonehardware.com.au